

Excellent performance

Easy operation

Various function

Stable & long life



CAS 160
CAS 250
CAS 350



The primary components of a product may not correspond with the image on catalog

FEATURES

1. Dividable structure at regular intervals in every 5 degree
2. Control function in 60° - - 60°(120°)
3. Easy system for regulating of degree and setting
4. Special frame to prevent interval by vibration in operation
5. Patent no. : 10-2005-0052454
6. High grade and light weight of aluminum stand
7. T-handle frame for easy setting and removal of motor
8. Using of heli coil for improvement of durability of base
9. Optional wheel for easy shift

Specification

ITEM	CAS 160	CAS 250	CAS 350
Capacity (")	6	10	12, 14
Angle of division (°)	5	5	5
Max. Angle (°)	±60	±60	±60
Max. Inter val (°)	0.82	0.82	0.82
Base size (mm)	228x180x116.5	228x180x116.5	300x194x114
Effectual Length (mm)	490	525	600
Stand	□ 49	□ 55	□ 59
Weight (kg)	9.4	10.6	17

The specification of machine is subject to change for the quality improvement without notice



Size of product

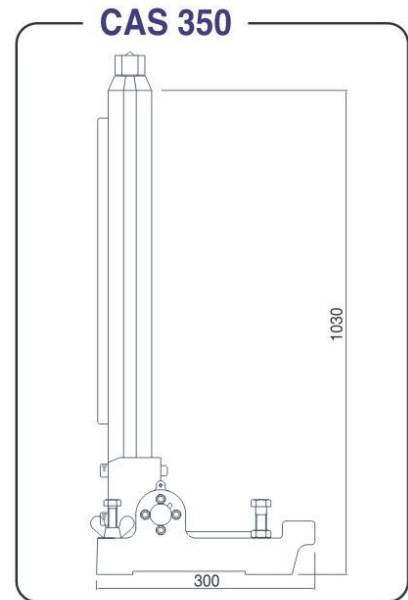
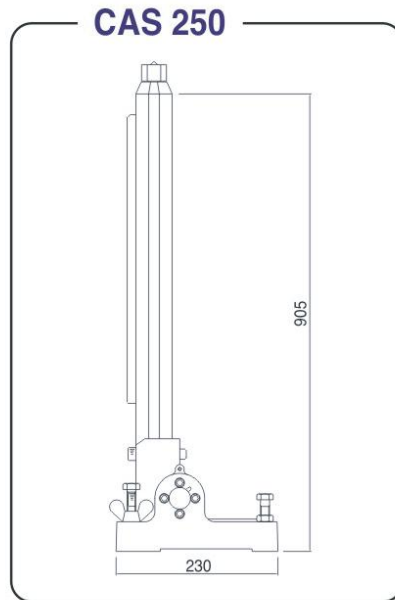
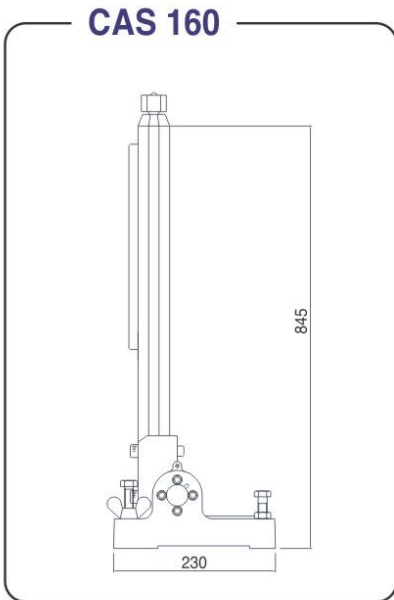

Features of product

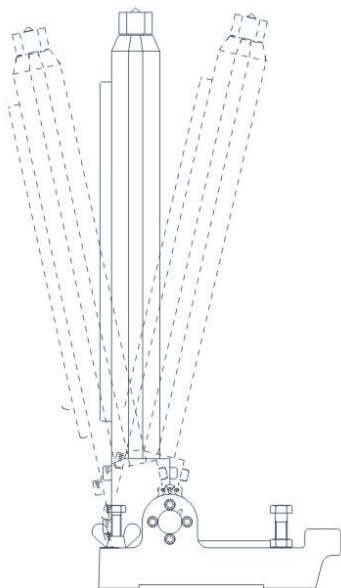

1. Ratchet(A).(B)



2. Pipe holder

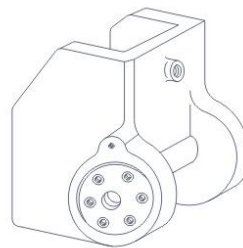

3. Heli coil



DISTRIBUTION

The specification of machine is subject to change for the quality improvement without notice

