

# DYNATEC

• Quality • Reliability • Peace of mind

## PRODUCTS CATALOGUE

### MATERIAL HANDLING SERIES



CONCRETE CUT  
MARKETING

# DYNATEC

• Quality • Reliability • Peace of mind

## HAND PALLET TRUCK (3 TONS)

The Hand Pallet Truck is the ideal "storage aid" and "handling partner" for all manual transport tasks over short distances excellently suitable for use on lorries, in the small warehouses and market etc

### 3-Position Handle for easy, safe use

- Upright position lowers the load with dampened hydraulics, handle springs back to the upright position automatically.
- Neutral position for moving loads. **210 degree pivot** allows exceptional manoeuvrability in tight spaces.
- Lowered position raises loads up to **3 tons, up to 195mm.**

### Frame

- A rugged heavy-duty frame constructed of one-piece formed channel steel offers incredible strength to the frame and our powder coated finish ensure long life protection.

### Forks

- Reinforced with tapered ends and helper roller for easy pallet entry and exit.

### Load Rollers

- Features polyurethane load rollers with sealed bearings. Adjustable Push Rods
- The adjustable push rods allow for individual adjustment of either fork height.

Model	DTPT-3T
Capacity (kg)	3000
Min. Fork Height H (mm)	80
Max. Fork Height H1 (mm)	190 – 200
Max. Lifting Height (mm)	>110
Fork Width B (mm)	685
Fork Length L (mm)	1200
Fork Size (mm)	160 x 60
Tandem Loading Wheel (mm)	Φ 80 x 70
Steering Wheel (mm)	Φ 180 x 50
Material of Wheel (mm)	Nylon/ PU
Net Weight (kg)	78/80

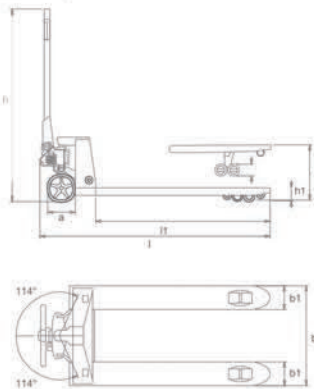

### Precaution

1. Check the hydraulic system and check the wheel, make sure it goes smoothly. The cargo should be placed orderly on the pallet.
2. Make sure the hand pallet insert fully into the middle of the pallet.
3. Lift the hand pallet in a proper height, and keep it balanced.
4. Pull the pressure relief handle to the low position and pull out the hand pallet truck, after the cargo reaching the right place.



CONCRETE CUT  
MARKETING



# MATERIAL HANDLING

## HAND PALLET TRUCK- NARROW TYPE (3 TONS)

The Hand Pallet Truck is the ideal "storage aid" and "handling partner" for all manual transport tasks over short distances excellently suitable for use on lorries, in the small warehouses and market etc

### 3-Position Handle for easy, safe use

- Upright position lowers the load with dampened hydraulics, handle springs back to the upright position automatically.
- Neutral position for moving loads. **210 degree pivot** allows exceptional manoeuvrability in tight spaces.
- Lowered position raises loads up to **3 tons, up to 195mm**.

### Frame

- A rugged heavy-duty frame constructed of one-piece formed channel steel offers incredible strength to the frame and our powder coated finish ensure long life protection.

### Forks

- Reinforced with tapered ends and helper roller for easy pallet entry and exit.

### Load Rollers

- Features polyurethane load rollers with sealed bearings. Adjustable Push Rods
- The adjustable push rods allow for individual adjustment of either fork height.

Model	DTPT-3NT (NT)
Capacity (kg)	3000
Min. Fork Height H (mm)	80
Max. Fork Height H1 (mm)	190 – 200
Max. Lifting Height (mm)	>110
Fork Width B(mm)	550
Fork Length L(mm)	1200
Fork Size (mm)	160 x 60
Tandem Loading Wheel (mm)	Φ 80 x 70
Steering Wheel (mm)	Φ 180 x 50
Material of Wheel (mm)	Nylon/ PU
Net Weight (kg)	78/80

### Precaution

1. Check the hydraulic system and check the wheel, make sure it goes smoothly. The cargo should be placed orderly on the pallet.
2. Make sure the hand pallet insert fully into the middle of the pallet.
3. Lift the hand pallet in a proper height, and keep it balanced.
4. Pull the pressure relief handle to the low position and pull out the hand pallet truck, after the cargo reaching the right place.



No. 18, Jalan Marikh U5/177, Seksyen U5,  
40150 Shah Alam, Selangor Darul Ehsan,  
Malaysia



[sales@concretecut.com.my](mailto:sales@concretecut.com.my)



+60378320743



## HAND PALLET TRUCK (5 TONS)

5.0 Ton Hand Pallet Truck is an economic & effortless solution for loading and unloading super-heavy goods, The heavy duty steel construction and effortless pump unit with super-large piston to reduce operating efforts.

### 3- Position Handle for easy, safe use

- Upright positions lowers the load with dampened hydraulics, handle springs back to the upright position automatically.
- Neutral position for moving loads. **210 degree** pivot allows exceptional manoeuvrability in tight spaces.
- Lowered position raises loads up to **3 tons, up to 195mm.**

### Frame

- A rugged heavy-duty frame constructed of one-piece formed channel steel offers incredible strength to the frame and our powder coated finish ensure long life protection.

### Forks

- Reinforced with tapered ends and helper roller for easy pallet entry and exit.

### Load Rollers

- Features polyurethane load rollers with sealed bearings.

### Adjustable Push Rods

- The adjustable push rods allow for individual adjustment of either fork height.

Model	DTPT-5T
Capacity (kg)	5000
Min. Fork Height H (mm)	80
Max. Fork Height H1 (mm)	195
Max. Lifting Height (mm)	>110
Fork Width B (mm)	685
Fork Length L (mm)	1200
Fork Size (mm)	180 x 50
Tandem Loading Wheel (mm)	Φ 80 x 70
Steering Wheel (mm)	Φ180 x 50
Material of Wheel (mm)	Nylon/ PU
Net Weight (Kg)	78/80

### Options

Bracket available with channel steel fork or 6mm thick steel Plate, Steering and fork wheels available super strength nylon or steel.



Super - heavy duty hydraulic pump



# MATERIAL HANDLING

## MANUAL STACKER



Model	DTMS-1T	DTMS-2T	DTMS-3T
Capacity (Ton)	1	2	3
Lifting height (mm)	1600	1600	1600
The Material of Shelf	Steel	Steel	Steel
The Lowest Fork Length (mm)	85	85	100
Fork Length (mm)	900	900	900
Adjust for Fork Width (mm)	230-580	270-680	320-770
Lift Speed (mm/Stroke)	24	14	10
Width (mm)	750	750	750
The Front Wheel Size (mm)	Φ 85 x 50	Φ 85 x 50	Φ 100 x 50
The Back Wheel Size (mm)	Φ 180 x 50	Φ 180 x 50	Φ 180 x 50
Whole Size (mm)	2040x750x1420	2050x750x1480	2050x800x1650
Weight (kg)	125	160	180

### Instructions

- Robust steel construction.
- It can be operated in a narrow space due to small turning radius. Lifting function operated by foot or hand controls.
- The strong frame provides more stable and safety lifting. Forged fork.
- Suitable for smooth and hard floor.
- Over load is prohibited.



No. 18, Jalan Marikh U5/177, Seksyen U5,  
40150 Shah Alam, Selangor Darul Ehsan,  
Malaysia



[sales@concretecut.com.my](mailto:sales@concretecut.com.my)



+60378320743



# DYNATEC

• Quality • Reliability • Peace of mind

## MINI ELECTRICAL HOIST

5.0 Ton Hand Pallet Truck is an economic & effortless solution for loading and unloading super-heavy goods, The heavy duty steel construction and effortless pump unit with super-large piston to reduce operating efforts.

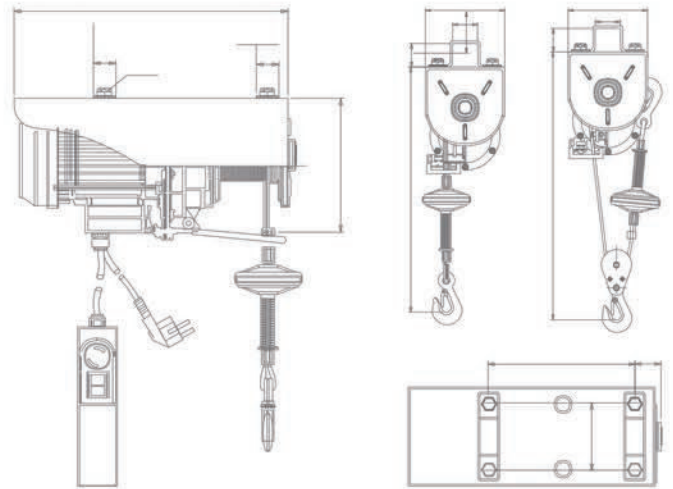

- With Emergency Stop Switch
- Reinforced Braking Switch with Position Limit
- Protection Class Up To IP54
- With Thermal Prevention Device

Model	PA250	PA500	PA800	PA1000
Method of use	Single – Hook	Single – Hook	Single – Hook	Single – Hook
Rated Volt (v)	220/230/240	220/230/240	220/230/240	220/230/240
Input Power (w)	510	1020	1300	1600
Lifting Weight (kg)	125	250	400	600
Lifting Speed (m/min.)	10	10	10	10
Lifting Height (m)	12	12	12	12
Qty/Ctn (pcs)	2	2	2	1
Packing Size (mm)	39 x 31 x 25	45 x 34 x 27	45 x 34 x 27	51 x 26 x 32
G.W / N.W (kg)	23.5 / 22.5	35/34	37.5 / 36.5	31/30



CONCRETE CUT  
MARKETING

## MINI ELECTRICAL HOIST

### Operating items

1. Anyone is strictly forbidden to stand under them when household electric hoist lifts heavy goods.
2. Regularly check whether the installation of household electric hoists is firm.
3. When lifting, it is not allowed to cable-stayed or diagonally lift heavy objects in order to avoid danger.
4. The installation position of the small electric hoist for household use must be selected in a place that meets the needs and is easy to operate.
5. When operating the wire rope, please wear thicker gloves. Please don't let the wire rope slip through your hands to avoid slipping or stabbing.
6. This household small electric hoist shall not carry people in any way, or as an elevator lifting tool.
7. When lifting a small electric hoist at home, be sure to keep at least 3 turns of wire rope on the rope drum to prevent the wire rope from falling off from the rope drum due to excessive force.
8. Please don't operate household small electric hoist when operator is in the case of alcohol, medicine and illness.
9. Please do not transform or weld the spare parts of small electric hoist optionally.
10. Please don't use household small electric hoist (German type mini electric winch) when be overload and don't clarity weight of lifting goods.



No. 18, Jalan Marikh U5/177, Seksyen U5,  
40150 Shah Alam, Selangor Darul Ehsan,  
Malaysia



[sales@concretecut.com.my](mailto:sales@concretecut.com.my)



+60378320743

# DYNATEC

• Quality • Reliability • Peace of mind



CONCRETE CUT  
MARKETING



No. 18, Jalan Marikh U5/177,  
Seksyen U5, 40150 Shah Alam,  
Selangor Darul Ehsan,  
Malaysia



[sales@concretecut.com.my](mailto:sales@concretecut.com.my)



+603-78320743